

## G package

JEDEC: TO-200AC

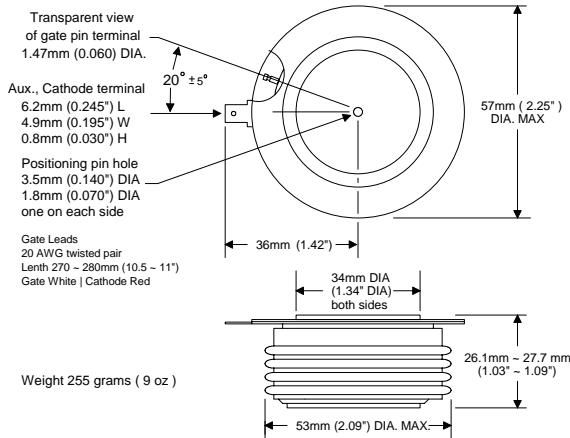

Part number scheme

**G T 07 N 18 KNX**

1 2 3 4 5 6

- 1) Package designation
- 2) Thyristor designation (i.e. SCR)
- 3) Series number
- 4) Designates standard recovery time
- 5) Voltage Multiplier (example: 18 x 100 = 1800)
- 6) Proprietary suffix

### Features:

- ✓ All diffused silicone.
- ✓ Center amplifying gate.
- ✓ Standard recovery time for phase control applications.
- ✓ Disk press package (nick named, Hockey Puck)
- ✓ Metal and ceramic package construction.
- ✓ Double side cooling.

### Voltage

Parameter	Symbol	Rating	Units
Maximum Repetitive Off-State Voltage <small>Notes: 1, 3, 4, 5, 6, 7</small>	V <sub>DRM</sub>	1600 ~ 2600	Volts
Maximum Repetitive Reverse Voltage <small>Notes: 1, 3, 4, 5, 6</small>	V <sub>RRM</sub>	1600 ~ 2700	Volts
Maximum non repetitive Surge of Reverse Voltage <small>Notes: 2, 3, 4, 5, 6</small>	V <sub>RSM</sub>	V <sub>RRM</sub> + 100	Volts
Critical rate of rising off-state Voltage, Linear to 80% of V <sub>DRM</sub> <small>Note: 2</small>	dv/dt	400	V/μs
<small>Note 1: T<sub>J</sub> 25°C. Note 2: T<sub>J</sub> 125°C. Note 3: Measured at the peak of the sine wave, Note 4: Below 0°C derate V<sub>DRM</sub> and V<sub>RRM</sub> 10%. Note 5: V<sub>DRM</sub> and V<sub>RRM</sub> have I<sub>DRM</sub>, I<sub>RRM</sub> of up to 35mA. Note 6: V<sub>DR</sub> and V<sub>RR</sub> have typical I<sub>DR</sub>, I<sub>RR</sub> of 2~7mA. Note 7: For DC applications derate V<sub>DRM</sub> 45%.</small>			
Specifying voltage:	1800V, GT07N18 1600V, GT07N16	2200V, GT07N22 2400V, GT07N24	2600V, GT07N26 Above 2600V inquire for availability.

### Gate

Parameter	Symbol	Rating			Units
		Temp.	Typ.	Max.	
Gate Trigger Voltage <small>Note 3</small>	V <sub>GT</sub>	-20°C 25°C 125°C	2.3 ~ 2.8 1.9 ~ 2.4 1.4 ~ 1.6	3	Volts
Maximum Gate Trigger Current <small>Notes 1, 3</small>	I <sub>GT</sub>		300		mA
Minimum Forward Current to Latch on-state <small>Notes 1, 5</small>	I <sub>L</sub>		800		mA
Maximum permissible Gate Voltage not to Trigger <small>Notes 1, 3</small>	V <sub>GDM</sub>		250		mV
Maximum permissible Gate Current not to Trigger <small>Notes 1, 3</small>	I <sub>GDM</sub>		10		mA
Maximum peak non repetitive Gate Voltage <small>Notes 2, 3</small>	V <sub>GM</sub>		8.4		Volts
Maximum Negative Gate Voltage <small>Notes 2, 4</small>	-V <sub>GM</sub>		5		Volts
Maximum non repetitive Gate Current <small>Notes 2, 3</small>	I <sub>GM</sub>		3.7		Amperes
Maximum Repetitive Gate Current <small>Notes 2, 3</small>	I <sub>GRM</sub>		1		Amperes
Average Gate Power (recommended) <small>Note 2, 3</small>	P <sub>GI(AVE)</sub>		0.9 ~ 3		Watts
<small>Note 1: T<sub>J</sub> 25°C. Note 2: T<sub>J</sub> 125°C. Note 3: Rectangular pulse, t<sub>p</sub> ≤ 8.3 ms. Note 4: Rectangular -V<sub>DC</sub> pulse, t<sub>p</sub> ≤ 8.3 ms. Note 5: Test conditions: I<sub>DC</sub> R<sub>L</sub> = 12Ω.</small>					

These graphs depict a typical device, each device has unique characteristics

### Gate Characteristics

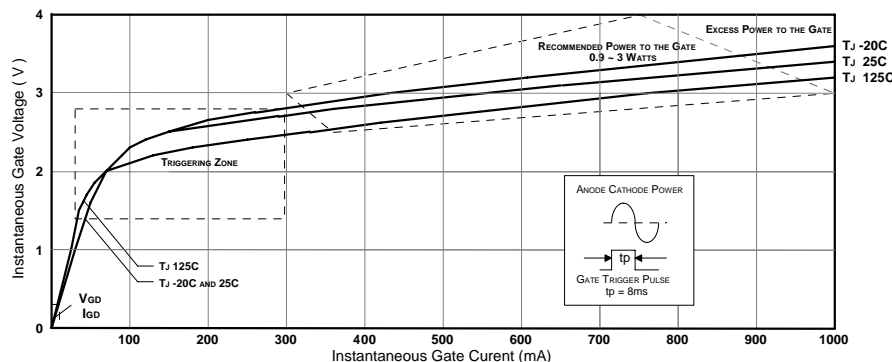

### Maximum non repetitive GATE POWER (PGM)

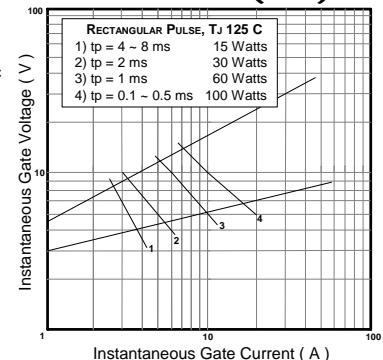

Amperage

Parameter	Symbol	Rating	Units
Maximum, Average, On state, Current <small>Notes: 3, 4</small>	$I_{T(AVE)}$	750	Amperes
Maximum, RMS, On state, Current <small>Notes: 3, 5</small>	$I_{T(RMS)}$	1150	Amperes
Maximum non repetitive, Surge, On state, Current, with no reverse voltage reapplied. <small>Notes: 2, 4</small>	$I_{TSM} 0\%V_{RRM}$	11	kA
Maximum non repetitive, Surge, On state, Current, with maximum reverse voltage reapplied. <small>Notes: 2, 4</small>	$I_{TSM} 100\%V_{RRM}$	9	kA
Critical rate of rising On-state Current, non repetitive <small>Note: 6, 7</small>	di/dt	400	A/ $\mu$ s
Holding Current <small>Notes: 1, 5</small>	$I_H$	400	mA
$I_{DR}$ = Repetitive, Off-State, leakage Current (typical) <small>Note: 1</small> $I_{RR}$ = Repetitive, Reverse, leakage Current. (typical) <small>Note: 1</small>	$I_{DR}$ & $I_{RR}$	2 ~ 7	mA
$I_{DRM}$ = Maximum (threshold), Repetitive, Off-State, Current. <small>Note: 1</small> $I_{RRM}$ = Maximum (threshold), Repetitive, Reverse, Current. <small>Note: 1</small>	$I_{DRM}$ & $I_{RRM}$	35	mA
Fuse's absolute maximum $I^2 t$ with no reverse voltage reapplied <small>Note: 2, 4</small>	$I^2 t, 0\% V_{RR}$	500	kA
Fuse's absolute maximum $I^2 t$ with up to 80% of $V_{RRM}$ reapplied <small>Note: 2, 4</small>	$I^2 t, \leq 80\% V_{RRM}$	370	kA
Reverse Recovery Charge ( $C_s$ = Stored Charge)	$Q_{RR}$	Consult factory	$\mu C_s$
<small>Note 1: <math>T_J</math> 25°C.      Note 2: <math>T_J</math> 125°C.      Note 3: <math>T_{CASE}</math> 55°C, double side air cooled.      Note 4: 180° conduction, 60Hz sine wave.                      Note 5: Test conditions: <math>I_{DC}</math> <math>R_L = 12\Omega</math>.      Note 6: Switching from <math>V_{DRM} \leq 1000V</math>      Note 7: In addition to 0.2<math>\mu</math>F and 20<math>\Omega</math> snubber circuit</small>			

These graphs depict a typical device, each device has unique characteristics

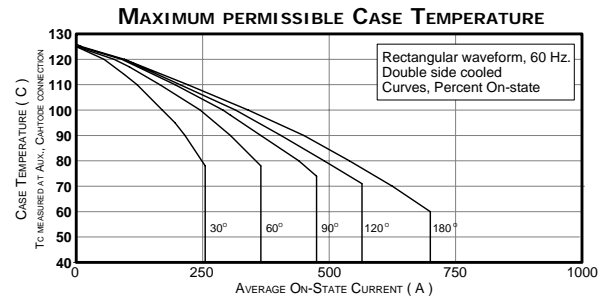
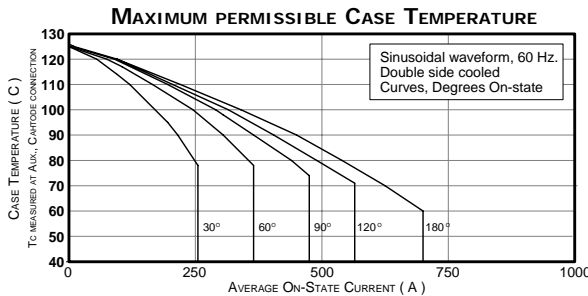
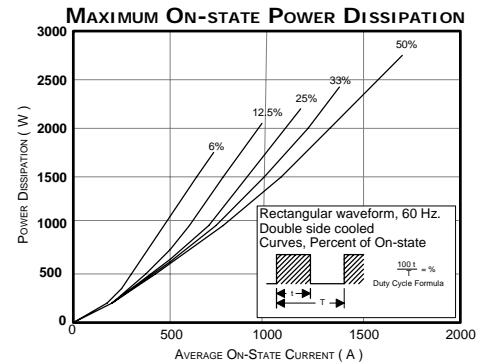
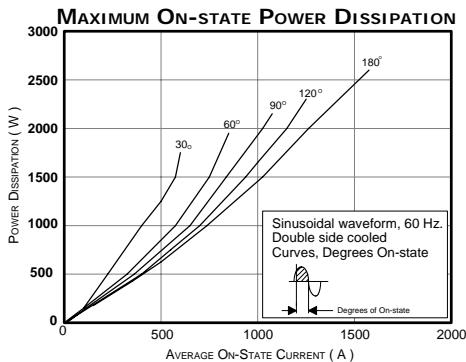
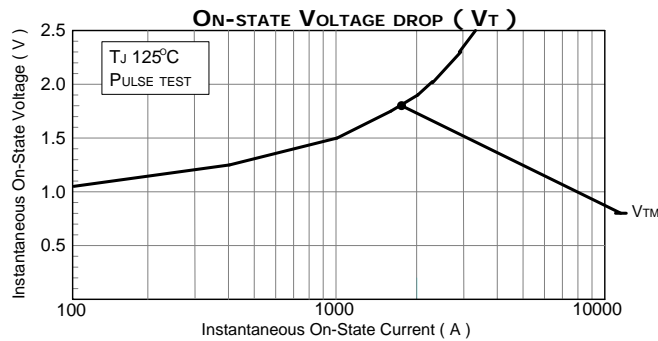

Thermal & Mechanical

Parameter	Symbol	Rating	Units
Operating Temperature Range	$T_J$	-40° ~ 125°	°Celsius
Maximum Thermal resistance, Junction to Case <small>Notes:1, 3, 5</small>	$R_{th-J-C}$	0.04	°C/W
Maximum Thermal resistance, Case to Heat Sink <small>Notes: 1, 2, 3, 4, 5</small>	$R_{th-C-HS}$	0.03	°C/W
Mounting Pressure		1360 ~ 1600 3000 ~ 3500	kg lb.
<small>Note 1: Recommended mounting pressure applied      Note 2: Mounting surfaces flat and greased      Note 3: Double side cooled                      Note 4: Case Temperature measured at aux., cathode      Note 5: 180° on-state</small>			