

## J package

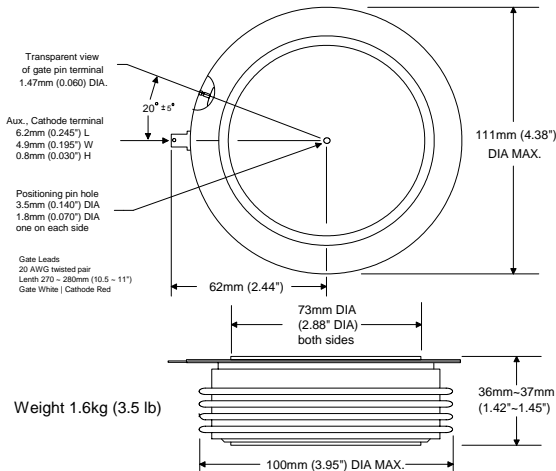

Part number scheme

**J T 17 N 45 KNX**  
 1 2 3 4 5 6

- 1) Package designation
- 2) Thyristor designation (i.e. SCR)
- 3) Series number
- 4) Designates standard recovery time
- 5) Voltage Multiplier (example: 45 x 100 = 4500)
- 6) Proprietary suffix

### Features:

- ✓ All diffused silicone.
- ✓ Center amplifying gate.
- ✓ Standard recovery time for phase control applications.
- ✓ Disk press package (nick named, Hockey Puck)
- ✓ Metal and ceramic package construction.
- ✓ Double side cooling.

## Voltage

Parameter	Symbol	Rating	Units
Maximum Repetitive Off-State Voltage <small>Notes: 1, 3, 4, 5, 6, 7</small>	$V_{DRM}$	3500 ~ 4500	Volts
Maximum Repetitive Reverse Voltage <small>Notes: 1, 3, 4, 5, 6</small>	$V_{RRM}$	3500 ~ 4500	Volts
Maximum non repetitive Surge of Reverse Voltage <small>Notes: 2, 3, 4, 5, 6</small>	$V_{RSM}$	$V_{RRM} + 100$	Volts
Critical rate of rising off-state Voltage, Linear to 80% of $V_{DRM}$ <small>Note: 2</small>	$dv/dt$	500	$V/\mu s$
<small>Note 1: <math>T_J</math> 25°C. Note 2: <math>T_J</math> 125°C. Note 3: Measured at the peak of the sine wave, Note 4: Below 0°C derate <math>V_{DRM}</math> and <math>V_{RRM}</math> 10%.                      Note 5: <math>V_{DRM}</math> and <math>V_{RRM}</math> have <math>I_{DRM}</math>, <math>I_{RRM}</math> of up to 50mA. Note 6: <math>V_{DR}</math> and <math>V_{RR}</math> have typical <math>I_{DR}</math>, <math>I_{RR}</math> of 3~7mA. Note 7: For DC applications derate <math>V_{DRM}</math> 45%.</small>			
Specifying voltage:	4000V, JT17N40		
	3500V, JT17N35	4500V, JT17N45	Above 4500V inquire for availability.

## Gate

Parameter	Symbol	Rating			Units
		Temp.	Typ.	Max.	
Gate Trigger Voltage <small>Note 3</small>	$V_{GT}$	-20°C	2.3 ~ 2.8	3	Volts
		25°C	1.9 ~ 2.4		
		125°C	1.4 ~ 1.6		
Maximum Gate Trigger Current <small>Notes 1,3</small>	$I_{GT}$		300		mA
Minimum anode cathode Current to Latch on-state <small>Notes 1, 5</small>	$I_L$		400		mA
Maximum permissible Gate Voltage not to Trigger <small>Notes 1,3</small>	$V_{GDM}$		250		mV
Maximum permissible Gate Current not to Trigger <small>Notes 1, 3</small>	$I_{GDM}$		10		mA
Maximum peak non repetitive Gate Voltage <small>Notes 2, 3</small>	$V_{GM}$		8.4		Volts
Maximum Negative Gate Voltage <small>Notes 2, 4</small>	$-V_{GM}$		5		Volts
Maximum non repetitive Gate Current <small>Notes 2, 3</small>	$I_{GM}$		3.7		Amperes
Maximum Repetitive Gate Current <small>Notes 2, 3</small>	$I_{GRM}$		1		Amperes
Average Gate Power (recommended) <small>Note 2, 3</small>	$P_{G(AVE)}$		0.9 ~ 3		Watts
<small>Note 1: <math>T_J</math> 25°C. Note 2: <math>T_J</math> 125°C. Note 3: Rectangular pulse, <math>t_p \leq 8.3</math> ms. Note 4: Rectangular <math>-V_{DC}</math> pulse, <math>t_p \leq 8.3</math> ms. Note 5: Test conditions: <math>I_{DC}</math> <math>R_L = 12\Omega</math>.</small>					

## Gate Characteristics

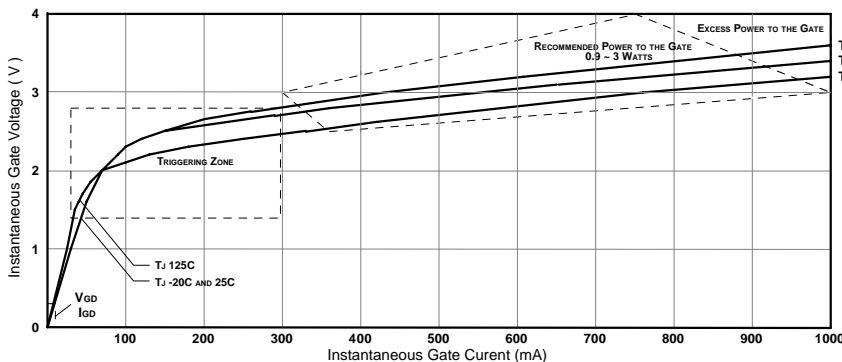

This graph depicts a typical device, each device has unique characteristics

## Maximum non repetitive GATE POWER (PGM)

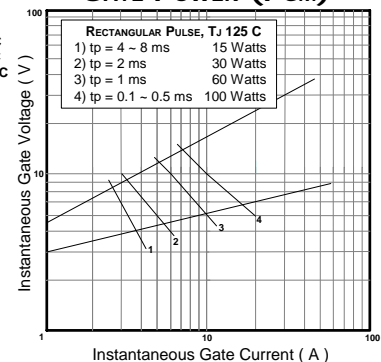

**Current**

Parameter	Symbol	Rating	Units
Maximum, Average, On state, Current <small>Notes: 3, 4</small>	$I_{T(AVE)}$	1650	Amperes
Maximum, RMS, On state, Current <small>Notes: 3, 4</small>	$I_{T(RMS)}$	2300	Amperes
Maximum non repetitive, Surge, On state, Current, with no reverse voltage reapplied. <small>Notes: 2, 4</small>	$I_{TSM} 0\% V_{RRM}$	Consult factory	kA
Critical rate of rising On-state Current, non repetitive <small>Note: 6, 7</small>	di/dt	1,200	A/ $\mu$ s
Critical rate of rising On-state Current <small>Note: 6, 7</small>	di/dt	500	A/ $\mu$ s
Holding Current <small>Notes: 1, 5</small>	$I_H$	250	mA
$I_{DR}$ = Repetitive, Off-State, leakage Current (typical) <small>Note: 1</small> $I_{RR}$ = Repetitive, Reverse, leakage Current. (typical) <small>Note: 1</small>	$I_{DR}$ & $I_{RR}$	3 ~ 7	mA
$I_{DRM}$ = Maximum (threshold), Repetitive, Off-State, Current. <small>Note: 1</small> $I_{RRM}$ = Maximum (threshold), Repetitive, Reverse, Current. <small>Note: 1</small>	$I_{DRM}$ & $I_{RRM}$	50	mA
Fuse's absolute maximum $I^2 t$ with no reverse voltage reapplied <small>Note: 2, 4</small>	$I^2 t, 0\% V_{RR}$	Consult factory	kA
Fuse's absolute maximum $I^2 t$ with up to 80% of $V_{RRM}$ reapplied <small>Note: 2, 4</small>	$I^2 t, \leq 80\% V_{RRM}$	Consult factory	kA
Reverse Recovery Charge ( $C_S$ = Stored Charge)	$Q_{RR}$	Consult factory	$\mu C_s$
Note 1: $T_J$ 25°C. Note 2: $T_J$ 125°C. Note 3: $T_{Case}$ 55°C, double side air cooled. Note 4: 180° conduction, 60Hz sine wave. Note 5: Test conditions: $I_{DC}$ $R_L = 12\Omega$ . Note 6: Switching from $V_{DRM} \leq 1000V$ Note 7: In addition to 0.2 $\mu$ F and 20 $\Omega$ snubber circuit			

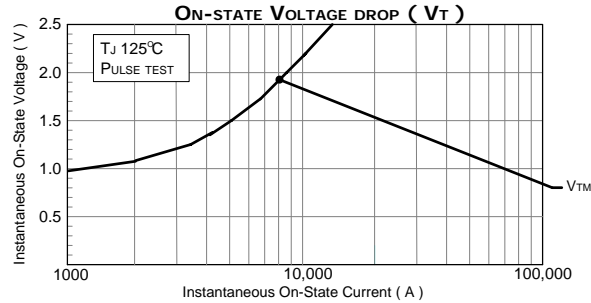

These graphs depict a typical device, each device has unique characteristics

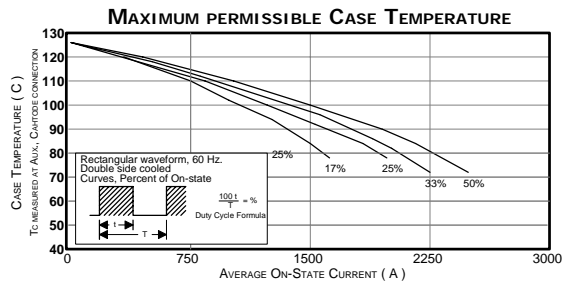
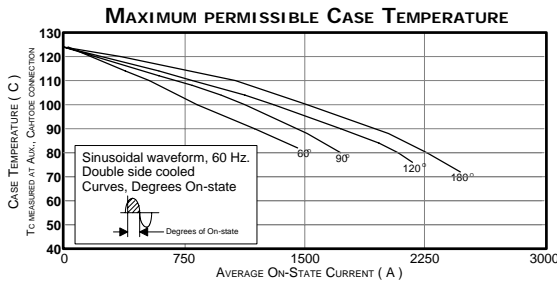
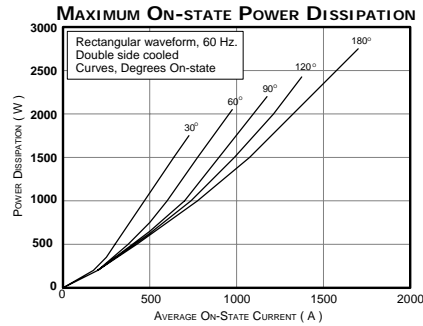
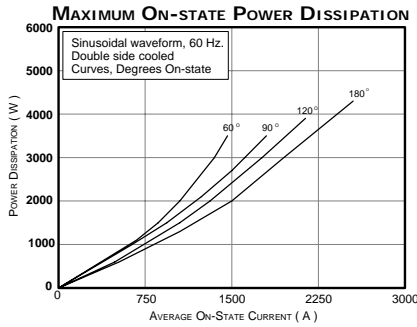

**Thermal & Mechanical**

Parameter	Symbol	Rating	Units
Operating Temperature Range	$T_J$	-40° ~ 125°	°Celsius
Maximum Thermal resistance, Junction to Case <small>Notes: 1, 3, 5</small>	$R_{th-J-C}$	0.012	°C/W
Maximum Thermal resistance, Case to Heat Sink <small>Notes: 1, 2, 3, 4, 5</small>	$R_{th-C-hs}$	0.002	°C/W
Mounting Pressure		3600 ~ 4500 8000 ~ 10000	kg lb.
Note 1: Recommended mounting pressure applied		Note 2: Mounting surfaces flat and greased	
Note 4: Case Temperature measured at aux., cathode		Note 3: Double side cooled	
Note 5: 180° on-state			