

Short Form Data Sheet

H package JEDEC DO-200AC

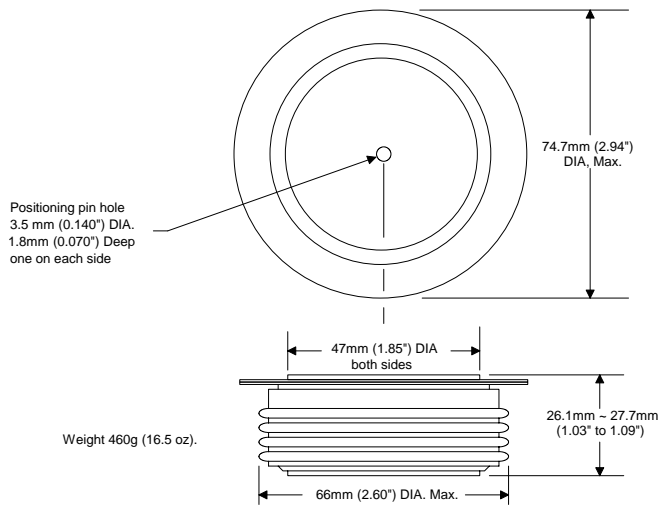

Part number scheme

H D 25 N 18 KNX
1 2 3 4 5 6

- 1) Package designation
- 2) Diode designation (i.e. Rectifier)
- 3) Series number
- 4) Designates standard recovery time
- 5) Voltage Multiplier (example: 18 x 100 = 1800)
- 6) Proprietary suffix

Features:

- ✓ All diffused silicone.
- ✓ Disk press package (nick named, Hockey Puck)
- ✓ Metal and ceramic package construction.
- ✓ Double side cooling.

Voltage

Parameter	Symbol	Rating	Units
Maximum Repetitive Reverse Voltage <small>Notes: 1, 3, 4, 5, 6</small>	V_{RRM}	1600 ~ 2700	Volts
Maximum non repetitive Surge of Reverse Voltage <small>Notes: 2, 3, 4, 5, 6</small>	V_{RSM}	$V_{RRM} + 100$	Volts
<small>Note 1: T_J 25°C. Note 2: T_J 125°C. Note 3: Measured at the peak of the sine wave, Note 4: Below 0°C derate V_{DRM} and V_{RRM} 10%. Note 5: V_{DRM} and V_{RRM} have I_{DRM}, I_{RRM} of up to 50mA. Note 6: V_{DR} and V_{RR} have typical I_{DR}, I_{RR} of 2~7mA. Note 7: For DC applications derate V_{DRM} 45%.</small>			
Specifying voltage:	1800V, HD25N18 1600V, HD25N16	2200V, HD25N22 2400V, HD25N24	2600V, HD25N26 Above 2600V inquire for availability.

Current

Parameter	Symbol	Rating	Units
Maximum, Average Current <small>Notes: 3, 4</small>	$I_{F(AVE)}$	2,400	Amperes
Maximum, RMS Current <small>Notes: 3, 4</small>	$I_{F(RMS)}$	3,800	Amperes
Maximum non repetitive Surge Current with no reverse voltage reapplied. <small>Notes: 2, 4</small>	$I_{FSM} 0\% V_{RRM}$	32	kA
I_{RR} = Typical Repetitive, Reverse, Current. <small>Note: 1</small>	I_{RR}	3 ~ 7	mA
I_{RRM} = Maximum (threshold), Repetitive, Reverse, Current. <small>Note: 1</small>	I_{RRM}	50	mA
Fuse's absolute maximum $I^2 t$ with no reverse voltage reapplied <small>Note: 2, 4</small>	$I^2 t, 0\% V_{RR}$	4,300	kA
Reverse Recovery Charge (C_s = Stored Charge)	Q_{RR}	Consult factory	μC_s
<small>Note 1: T_J 25°C. Note 2: T_J 125°C. Note 3: T_{Case} 55°C, double side air cooled. Note 4: 180° conduction, 60Hz sine wave.</small>			

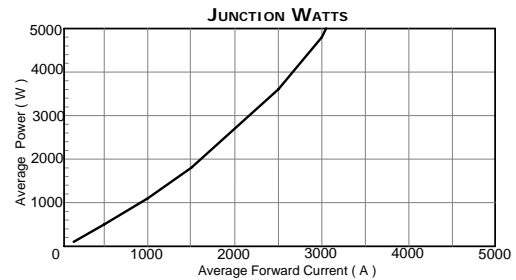
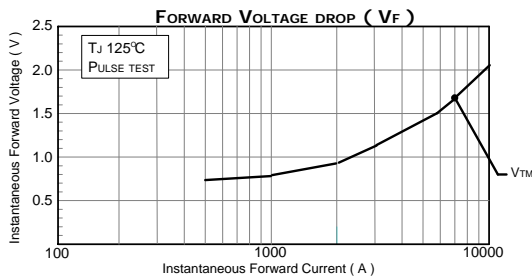

Thermal & Mechanical

Parameter	Symbol	Rating	Units
Operating Temperature Range	T_J	-40° ~ 180°	°Celsius
Maximum Thermal resistance, Junction to Case <small>Notes: 1, 3, 5</small>	R_{th-J-C}	0.023	°C/W
Maximum Thermal resistance, Case to Heat Sink <small>Notes: 1, 2, 3, 4, 5</small>	$R_{th-C-HS}$	0.01	°C/W
Mounting Pressure		2300 ~ 2700	kg
		5000 ~ 6000	lb.
Weight		460	Grams
		16.5	oz.
<small>Note 1: Recommended mounting pressure applied Note 2: Mounting surfaces flat and greased Note 3: Double side cooled Note 4: Case Temperature measured at cathode flange Note 5: 180° on-state</small>			